

Zestawienie dla 1 el. wysyłkowego		1/13		Suma		1 X Wykonać	
Poz.	Sztuk	Profil	Długość	Masa 1 poz.	Masa całk.	Materiał	Uwagi
1/1040	1	IPE160	2565	40.45	40.45	S235JR	
1/1041	1	HEA100	300	5.00	5.00	S235JR	
1/1049	1	PL12*86	373	2.95	2.95	S235JR	
Waga sumaryczna [kg]:					48.4		

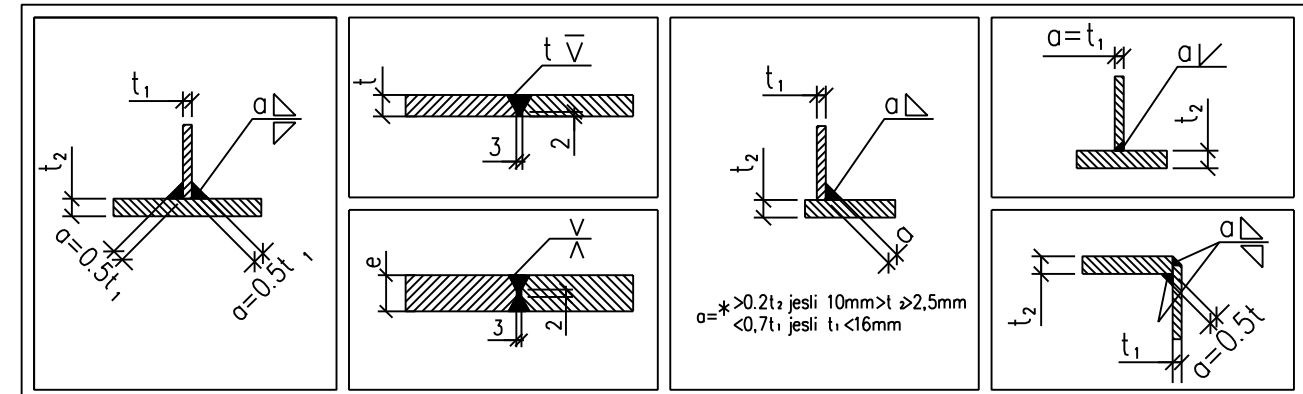

Widok 3D

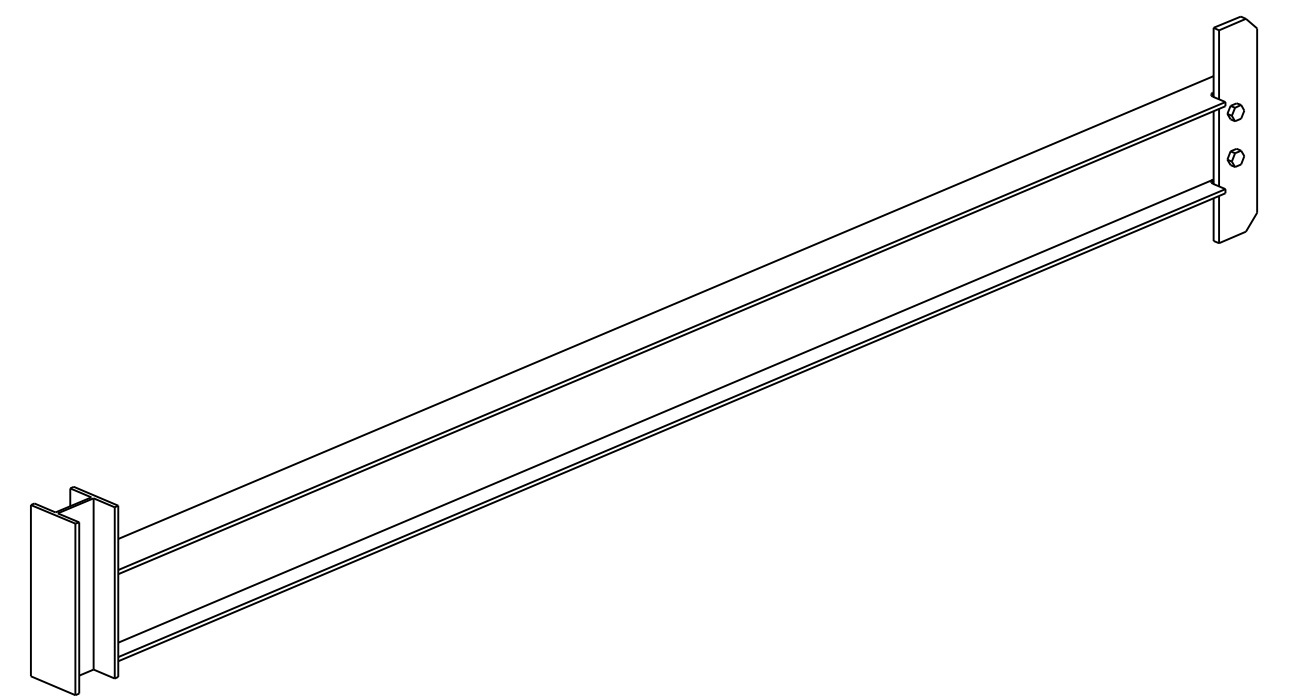

ZMIANY							
Modernizacja układu pompowego w Ciepłowni Sierpc. Konstrukcja wsporcza 1/13							Inwestor: Ciepłownia Sierpc ul. Przemysłowa 2a 09-200 Sierpc
Projektował	M. Ciepliński	07.2021	1:10	Nr rysunku:	B-0013		Nr projektu:
			A3				EP-04/21 T1
							Nr kolejny rysunku:
							39

