

Przekrój A - A

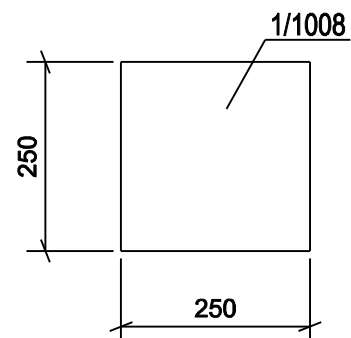

Zestawienie dla 1 el. wysyłkowego		1/8		Suma		1 X Wykonać	
Poz.	Sztuk	Profil	Długość	Masa 1 poz.	Masa całk.	Materiał	Uwagi
1/1006	1	PL12*250	250	5.89	5.89	S235JR	
1/1008	1	PL12*250	250	5.89	5.89	S235JR	
1/1012	1	HEA100	195	3.25	3.25	S235JR	
Waga sumaryczna [kg]:					15.0		

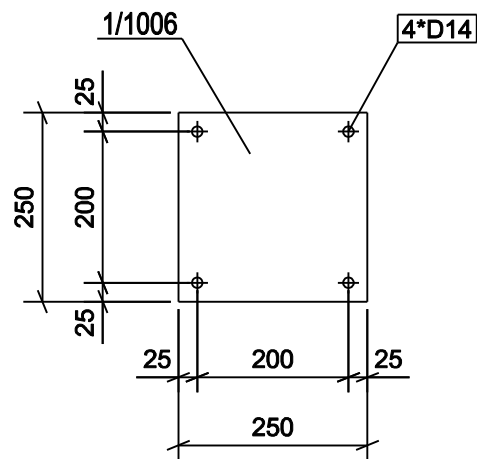
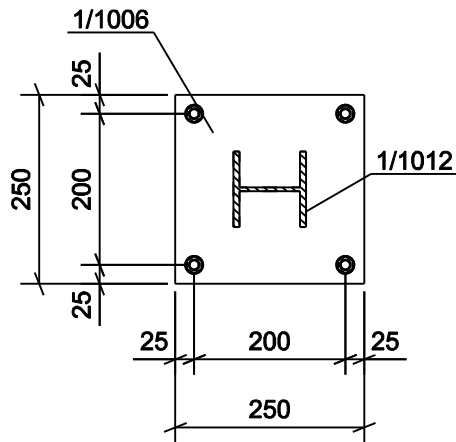
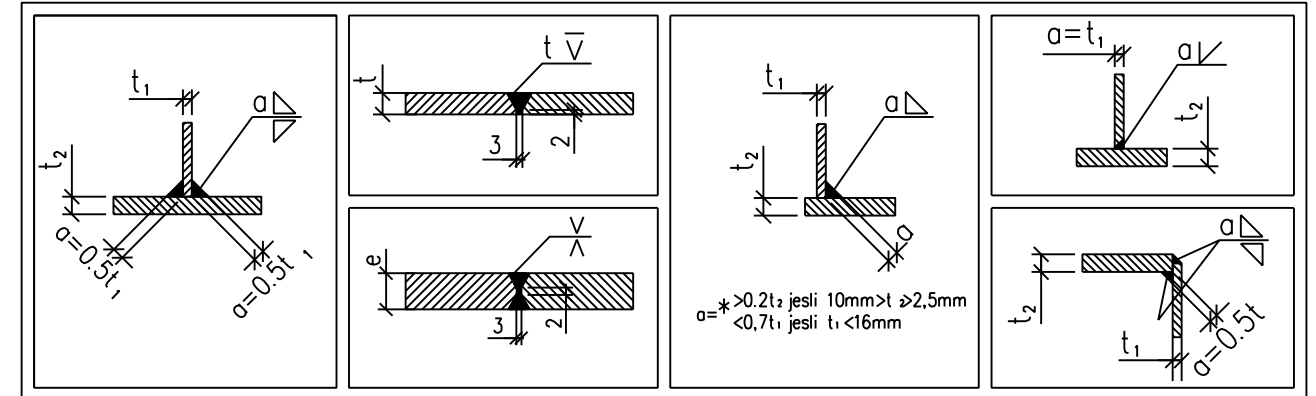

Widok 3D

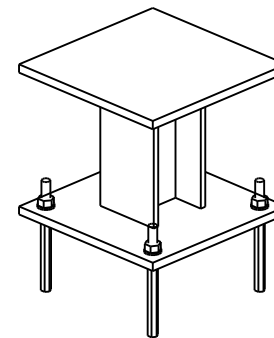

ZMIANY							
Modernizacja układu pompowego w Ciepłowni Sierpc. Konstrukcja wsporcza 1/8						Inwestor: Ciepłownia Sierpc ul. Przemysłowa 2a 09-200 Sierpc	
Projektował	M.Ciepliński	07.2021	1:10	Nr rysunku:	B-0008		Nr projektu: EP-04/21 T1
			A3			Nr kolejny rysunku: 34	