

Przekrój B - B

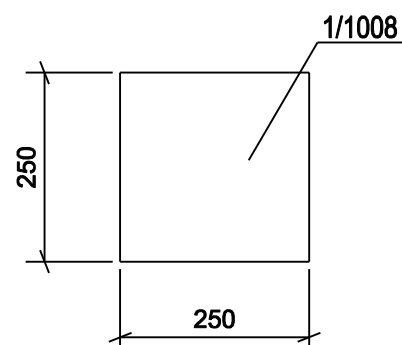

Zestawienie dla 1 el. wysyłkowego		1/7	Suma		1	X	Wykonać
Poz.	Sztuk	Profil	Długość	Masa 1 poz.	Masa całk.	Materiał	Uwagi
1/1006	1	PL12*250	250	5.89	5.89	S235JR	
1/1008	1	PL12*250	250	5.89	5.89	S235JR	
1/1009	1	HEA100	150	2.50	2.50	S235JR	
Waga sumaryczna [kg]:					14.3		

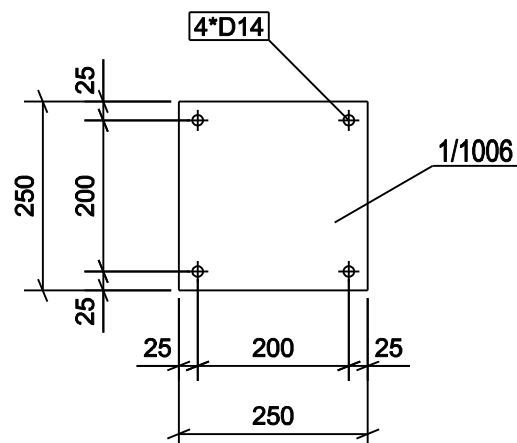
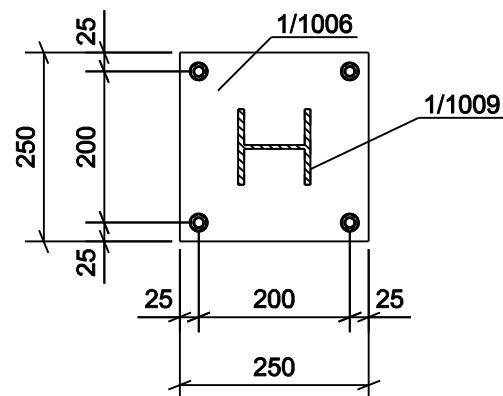
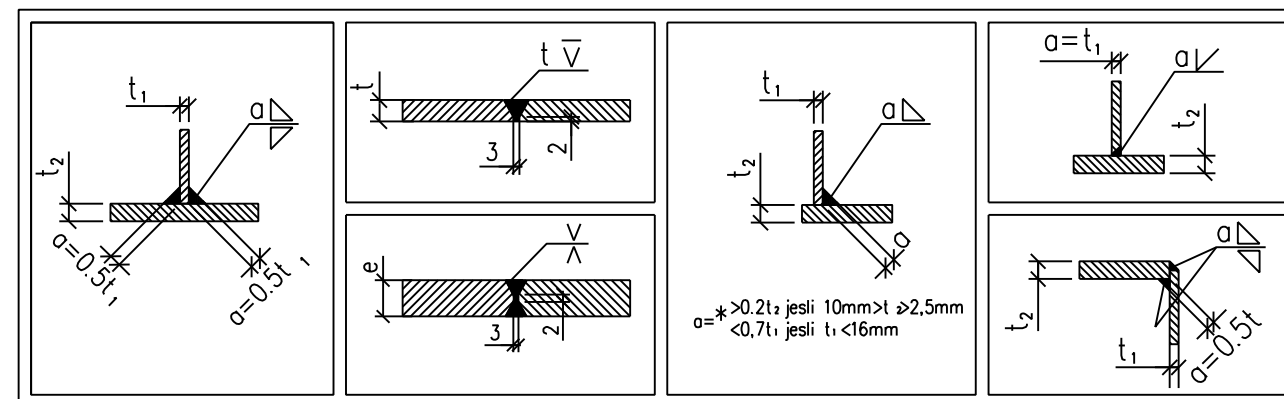

Widok 3D

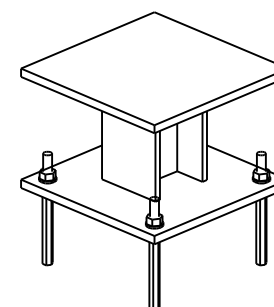

ZMIANY							
Modernizacja układu pompowego w Ciepłowni Sierpc. Konstrukcja wsporcza 1/7						Inwestor: Ciepłownia Sierpc ul. Przemysłowa 2a 09-200 Sierpc	
Projektował	M.Ciepliński	07.2021	1:10	Nr rysunku:	B-0007		Nr projektu: EP-04/21 T1
			A3			Nr kolejny rysunku: 33	