

Przekrój A - A

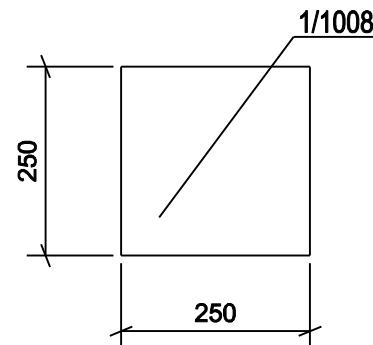

Zestawienie dla 1 el. wysyłkowego		1/5		Suma		1 X Wykonać	
Poz.	Sztuk	Profil	Długość	Masa 1 poz.	Masa całk.	Materiał	Uwagi
1/1006	1	PL12*250	250	5.89	5.89	S235JR	
1/1007	1	HEA100	307	5.12	5.12	S235JR	
1/1008	1	PL12*250	250	5.89	5.89	S235JR	
Waga sumaryczna [kg]:					16.9		

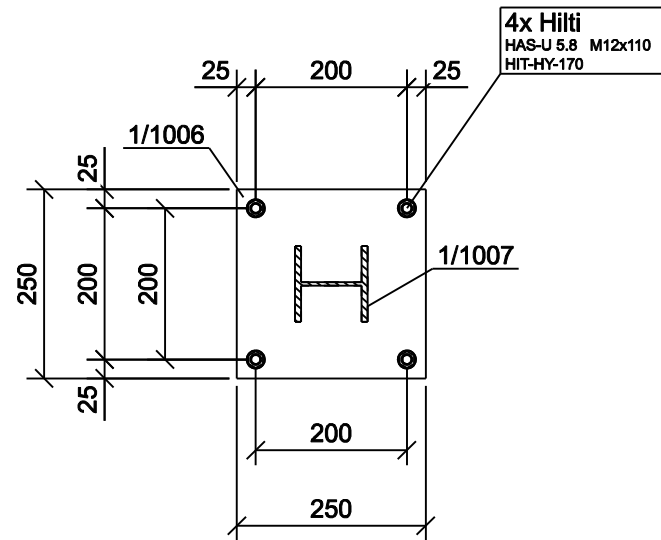
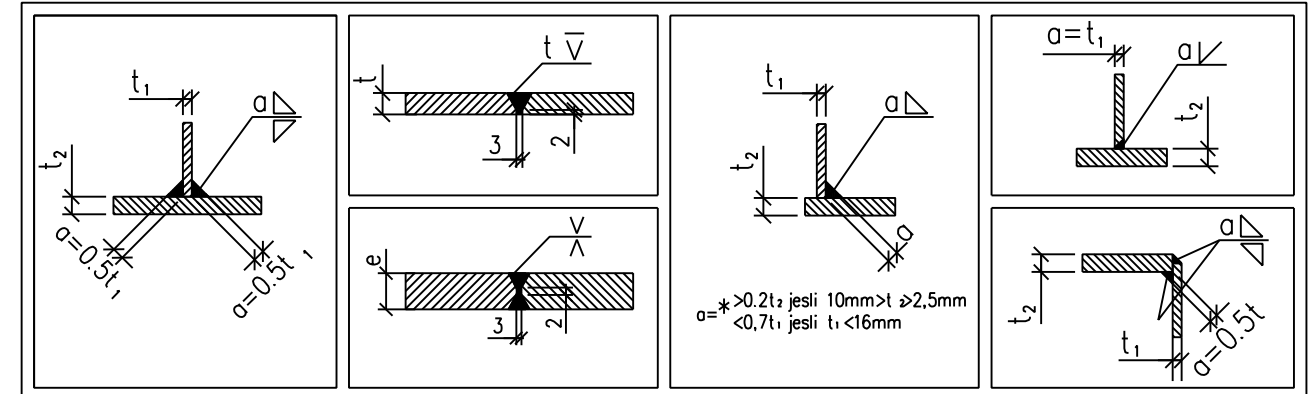

Widok 3D

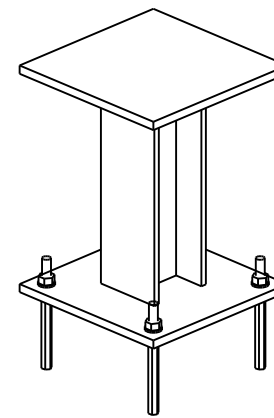

ZMIANY							
Modernizacja układu pompowego w Ciepłowni Sierpc. Konstrukcja wsporcza 1/5						Inwestor: Ciepłownia Sierpc ul. Przemysłowa 2a 09-200 Sierpc	
Projektował	M. Ciepliński	07.2021	1:10	Nr rysunku:	B-0005	Nr projektu: EP-04/21 T1	
			A3			Nr kolejny rysunku: 31	
		<small>ul. Na Złapczu 20 87-100 Toruń tel: 56 / 639 12 10 fax: 56 / 639 12 11 www.elektromontaz-torun.pl biuro@elektromontaz-torun.pl</small>				<small>INSTALACJE ELEKTROENERGETYCZNE AUTOMATYKA PRZEMYSŁOWA KOMPUTEROWE SYSTEMY STEROWANIA</small>	